

Q1.The article gives some information about graphene.

🎵 Nanotunes! 🎵

Carbon can be made into nano-thin, strong sheets called graphene.

A graphene sheet is a single layer of graphite.

Graphene conducts electricity and is used in loudspeakers.

The picture shows the structure of graphene.



© Jimmy/iStock

(a) Use the picture and your knowledge of bonding in graphite to:

(i) explain why graphene is strong;

.....

.....

.....

.....

.....

.....

(3)

(ii) explain why graphene can conduct electricity.

.....
.....
.....
.....
.....
.....

(2)

(b) Graphite is made up of layers of graphene.

Explain why graphite is a lubricant.

.....
.....
.....
.....

(2)

(Total 7 marks)

Q2.Oil rigs are used to drill for crude oil.



© Digital Vision/Photodisc

(a) Drill heads are made from steel. Steel is an alloy.

Explain why alloys are harder than pure metals.

.....

.....

.....

.....

.....

.....

(3)

(b) Drill heads also contain diamonds.

Describe, as fully as you can, the structure and bonding in diamond.

.....

.....

.....

.....

.....

.....

.....
.....

(4)

(c) Polymers are produced from crude oil.

Describe the structure and bonding in a thermosoftening polymer and explain why thermosoftening polymers melt when heated.

.....
.....
.....
.....
.....
.....
.....
.....
.....

(4)

(Total 11 marks)

Q3. Scientists have recently developed a method to produce large sheets of a substance called graphene.

Graphene is made from carbon and is a single layer of graphite just one atom thick.

The properties of graphene include:

- it conducts electricity
- it is transparent since it is only one atom thick
- it is strong and durable.



These properties make it suitable to overlay a monitor screen to make it a touchscreen.

The photograph below shows the structure of graphene.

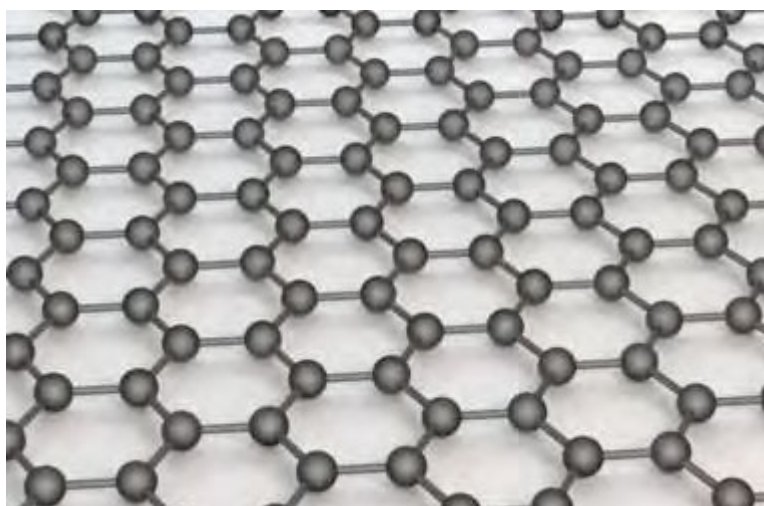

Photographs supplied by iStockphoto/Thinkstock

Use your knowledge of the bonding in graphite and the photograph of the structure to help you to explain, as fully as you can:

(a) (i) why graphene is strong;

.....

.....

.....

.....

.....

.....

(3)

(ii) why graphene conducts electricity.

.....
.....
.....
.....
.....

(2)

(b) Suggest why a sheet of graphite which has a large number of carbon layers would not be suitable for the touchscreen.

.....
.....

(1)

(Total 6 marks)

Q4. Graphite and diamond are different forms of the element carbon. Graphite and diamond have different properties.

The structures of graphite and diamond are shown below.

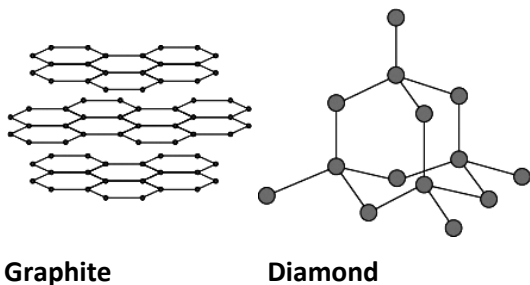

(a) Graphite is softer than diamond.

Explain why.

.....

.....

.....

.....

.....

.....

.....

.....

(4)

(b) Graphite conducts electricity, but diamond does not.

Explain why.

.....

.....

.....

.....
.....
.....

(3)
(Total 7 marks)

Q5. Diamonds are used as abrasives.

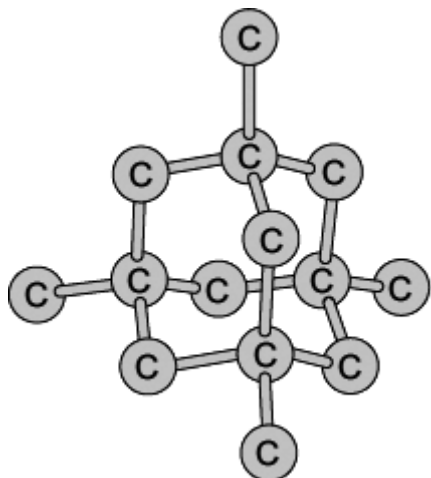

Model of part of the diamond structure

Diamonds are very hard.
Explain why.

A good answer will include information on the structure and bonding in diamonds.

.....

.....

.....

.....

.....

.....

.....

.....

.....

(3)
(Total 3 marks)

Q6. The picture shows a copper kettle being heated on a camping stove.

Copper is a good material for making a kettle because:

- it has a high melting point
- it is a very good conductor of heat.

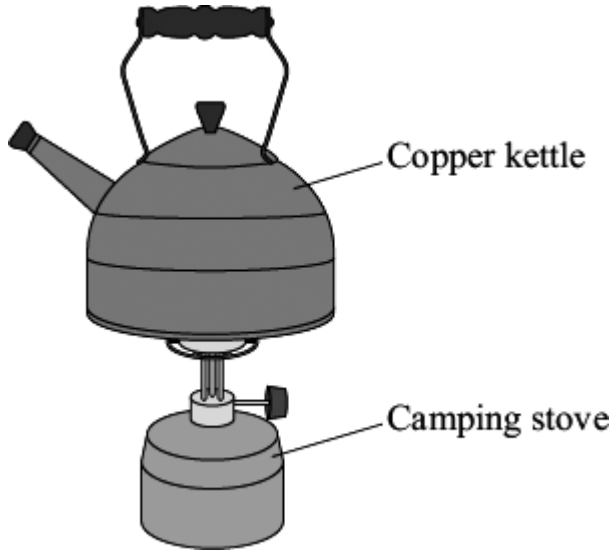

(a) Explain why copper, like many other metals, has a high melting point. You should describe the structure and bonding of a metal in your answer.

.....

.....

.....

.....

.....

.....

.....

.....

(4)

(b) An aeroplane contains many miles of electrical wiring made from copper. This adds to the mass of the aeroplane.

It has been suggested that the electrical wiring made from copper could be replaced by lighter carbon nanotubes.

The diagram shows the structure of a carbon nanotube.

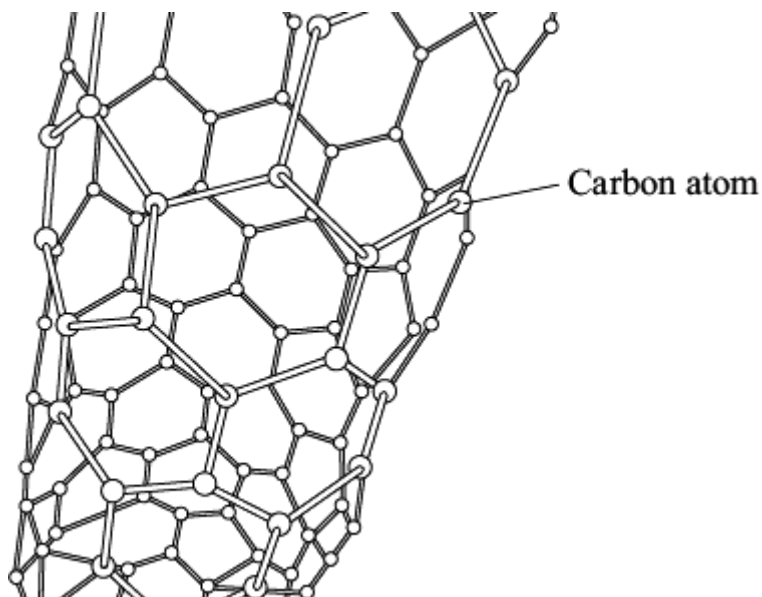

(i) What does the term 'nano' tell you about the carbon nanotubes?

.....
.....

(1)

(ii) Like graphite, each carbon atom is joined to three other carbon atoms.

Explain why the carbon nanotube can conduct electricity.

.....
.....
.....
.....

(2)

(Total 7 marks)

Q7. This drill contains an electric motor.

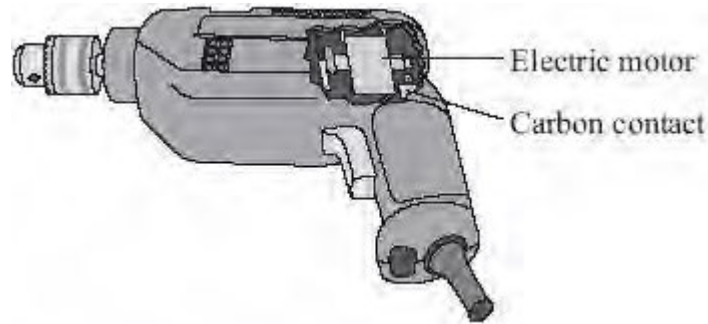

The diagram below shows the main parts of an electric motor.

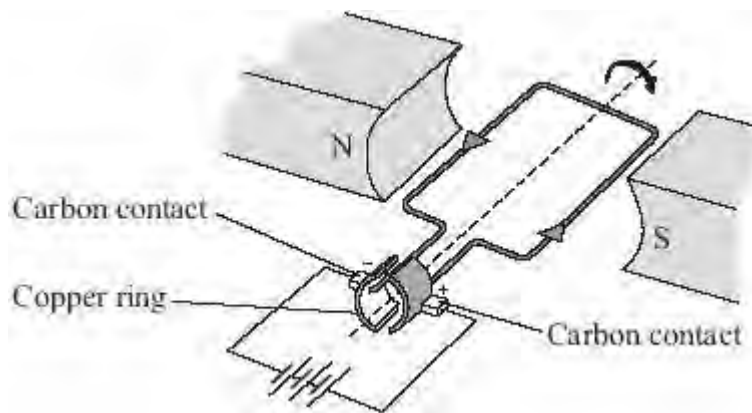

The carbon contacts are made of graphite. Springs push the contacts against the copper ring. The contacts conduct electricity to the copper ring. The copper ring rotates rapidly but does not stick or become worn because the graphite is soft and slippery.

Graphite has properties which are ideal for making the contacts in an electric motor.

Explain, in terms of structure and bonding, why graphite has these properties.

.....

.....

.....

.....

.....

.....

.....

.....

.....

.....

.....

.....

(Total 5 marks)